

Item No.:

Qty.:

Project:

CP NEXT



CP Next, the IRINOX multifunctional environmentally friendly R290 (Propane) holding cabinet. The all-in-one multidoor cabinet capable of operating as a holding refrigerator, freezer and chocolate holding cabinet. Precise air temperature control, variable humidity management, and even and consistent air distribution within the cabinet are just some of the features that are paramount in proper storage and the preservation of raw and prepared foods natural qualities like color, texture, and flavor. CP Next provides safely storing for your fresh and prepared foods in a temperature range of -13°F/-59°F. Store your creations uncovered for extended periods of time without compromising quality. More than 30 years of IRINOX know-how, innovation, connectivity, and quality construction in a single cabinet.

Capacity

	Double door
Number of trays (18"x 26") 1" 3/8 spacing	37
Number of trays (18"x 26") 2" spacing	26
Number of trays (18"x13") 1" 3/8 spacing	74
Number of trays (18"x13") 2" spacing	52

Standard construction details

- Door hinged right standard. (Opens left to right).
- Doors full width double beveled edges.
- Magnetic and slow closing doors.
- Ergonomic and robust handle made of steel.
- Internal lighting with double led bar.
- 4.3" capacitive touch screen display.
- Door seal with 5 chambers to guarantee a better temperature seal.
- Internal and external structure completely in AISI 304 stainless steel.
- Built-in air condensing unit.
- High efficiency cooling system with R290 natural refrigerant gas.
- Fast, effective, innovative adaptive hot gas defrosting allows you to manage and set cycle times, to avoid sudden changes in the storage temperature.
- Adaptive smart defrosting with the possibility of setting the time bands of use.
- Top side with a thickness of 5.31" in high-density polyurethane foam
- Bottom, back of the cabinet and stainless steel door with a thickness of 3.54"; sides with 3.14" high-density polyurethane foam
- Evaporating compartment shell with a thickness of 1.57" thick high-density polyurethane foam insulation.USB port for HACCP download.
- Innovative, patented air distribution system allows perfect air distribution on each shelf within the cabinet. Dual channel air delivery system generates three air flow dimensions, one central and two lateral ensuring uniform ventilation.
- Humidity management created by the perfect balance between the size of the evaporator, the power of the variable speed fans and the power of the compressor.

Item No.:

Qty.:

Project:

Operation

2 types of door available:

Double steel door: ideal for optimizing storage in case of intensive use with a high number of daily door openings.

Double glass door: ideal for optimizing storage in case of intensive use with a high number of daily door openings and when used as a display unit.

2 operating modes available:

Multi: with operating temperatures from -13° to +59°F, with the possibility of setting the conservator on 3 different temperatures: Negative (-13° / -59°), Chocolate (+50° / +59°) or Positive (+13° / +59°), for maximum flexibility of use.

Up: with operating temperatures from +23° to +59°F, with the possibility of setting the conservator on 2 different temperatures: Positive (+13° / +59°) or Chocolate (+50° / +59°).

Humidity management

Humidity regulation with the selection of 6 different humidity levels (from 40% to 95% RH). The humidity control is active only if the conservator temperature is above 32°F.

Interface

4.3" display with capacitive colour screen. Equipped with buzzer.

Connectivity

FreshCloud® is Irinox's IOT technology that allows you to control and interact with Cp Next at any time via an APP.

The application features are:

- Remote monitoring of the operation and parameters of the cycle in progress
- Push notification system
- Usage statistics viewing
- HACCP data backup

Optional

- Sanigen® (Irinox patented sanitization system).
- Pairs of additional tray guides.
- 4 swivel casters, 2 locking.
- Opposite door hinging kit.
- Stainless steel spacers for positioning several CP Next units side by side.
- Packing in HT wooden case.

Product warranty

- 2 years, parts and labor.
- 5 years, compressor.

Certification



Item No.:

Qty.:

Project:

CP NEXT

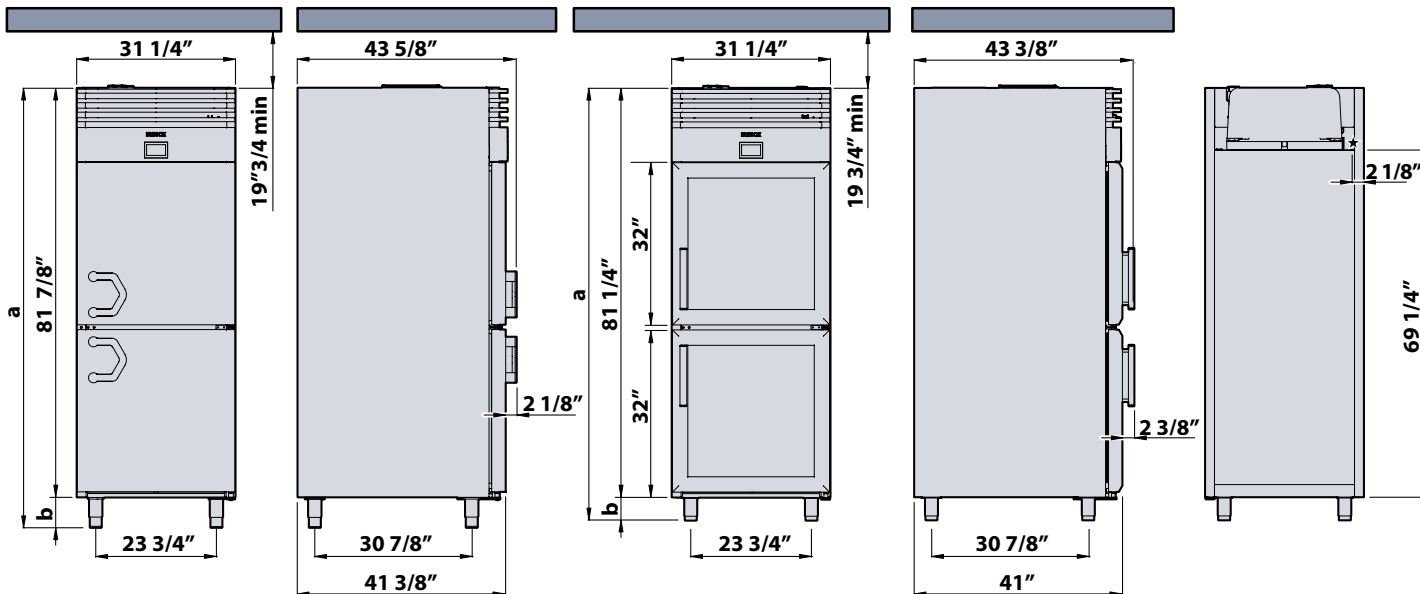

HEIGHT

		a	b
Standard feet	in	87" 1/8 - 89"	6" + 7" 7/8
Castors options	in	87" 5/16	6" 1/9

Measures in inches

★ Main power cable

TECHNICAL SPECIFICATIONS

		208V - 2+PE 60Hz			
		UP		MULTI	
Configuration		SOLID DOOR	GLASS DOOR	SOLID DOOR	GLASS DOOR
Power rating	W	700		1300	
Rated load amps (RLA)	A	3,45		8	
Maximum rating of overcurrent protective device (MOPD)	A	15		15	
Minimum circuit amps (MCA)	A	15		15	
Main power cable	AWG	2C + G 14AWG		2C + G 14AWG	
Refrigeration yield (14/+104°F; Tsuct +68°F; Subcooling 0°F)	btu/h	2367		5896	
MAX Condenser rating (23/+113°F; Tsuct +68°F; Subcooling 0°F)	btu/h	3502		8573	
MIN air flow for ventilation	ft³/h	24011		33545	
Refrigerant type	-	R290 - 5.29 oz		R290 - 5.29 oz	
Climate class	-	class 5 = 104°F - 40% relative humidity		class 5 = 104°F - 40% relative humidity	
Cabinet dimension (WIDTH x DEPTH)	in	31" 1/4 x 43" 5/8		31" 1/4 x 43" 5/8	
Internal cell dimension (WIDTH x DEPTH x HEIGHT)	in	25" x 32" 7/8 x 59" 1/16		25" x 32" 7/8 x 59" 1/16	
Cabinet weight	lb	463	518	463	518

INSTALLATION

Units must be clear of outside heat sources.

The content of the manual must be carefully followed to ensure the correct operation and to protect the rights of the end user based on the warranty. The CP NEXT must be installed by following and complying with the contents of the specific installation manual.

Continuous product development may require changes to specifications without notice.

Irinnox North America Inc.

9990 NW 14th Street, Suite 107 - Miami, FL 33172 U.S.A.

Tel. +1 786 870 5064 | info@irinnoxnorthamerica.com | www.irinnoxprofessional.com/usa